

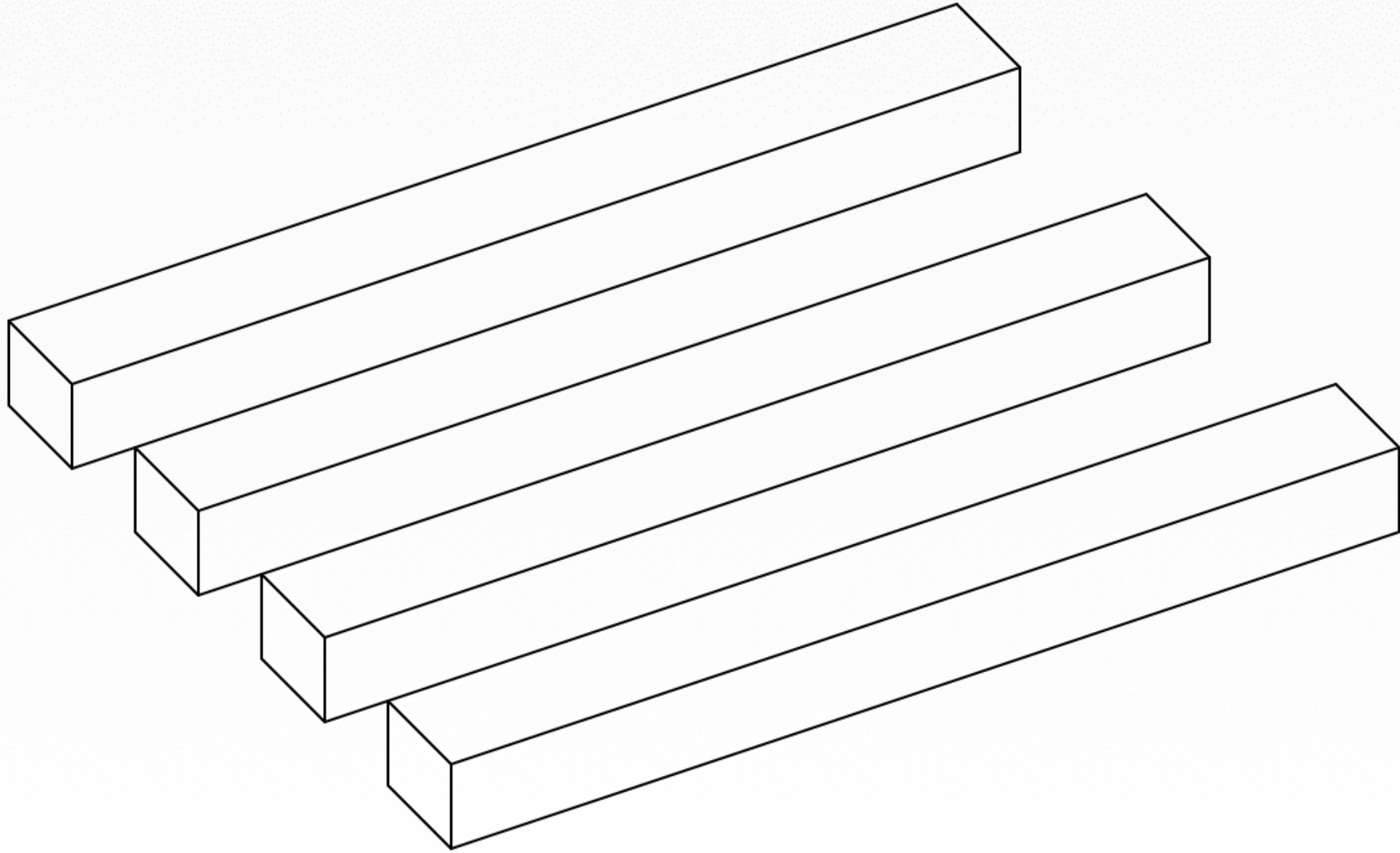

WEBINAR DE TOEKOMST VAN DE FINANCIËLE FUNCTIE

'DATA – VISUALISEREN & INTERPRETEREN'





Cijfermisleiding is geen nieuw probleem!

In 1954 bracht Darrell Huff er al een bestseller over uit: **'How to Lie with Statistics'**.

"Toch trappen we er een halve eeuw later nog steeds in. Hoe kan dat?"

Cijfers leiden, verleiden en misleiden.

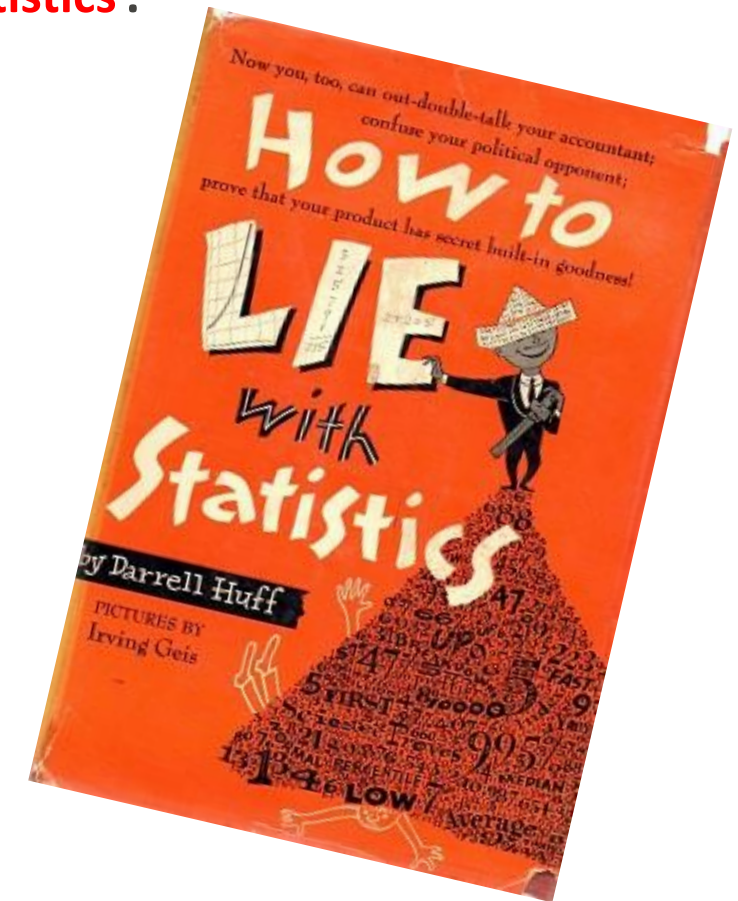

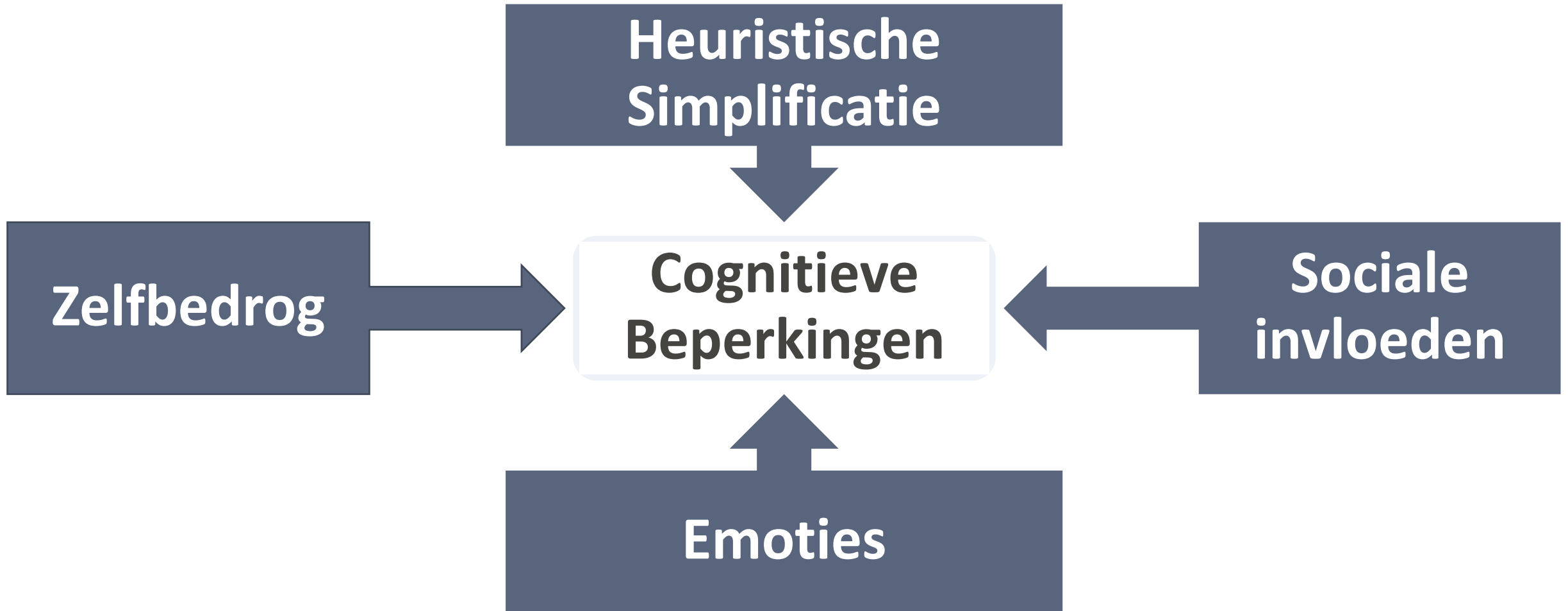

Toenemende data

Cloud data increases twentyfold towards 2030

Total data flow per year in ZB

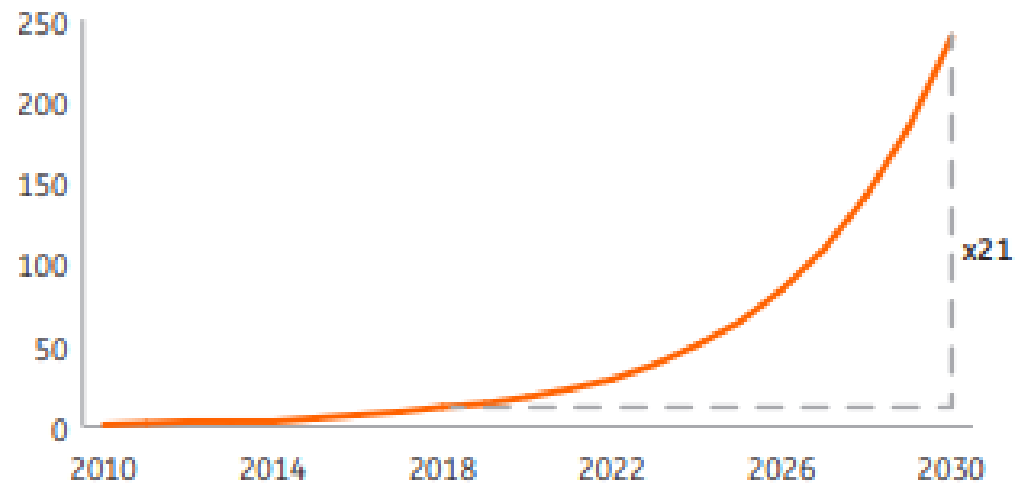

Source: ING Economics Department based on Cisco

Around 5% of global power needed for data flows

Electricity use as % of total electricity consumption worldwide

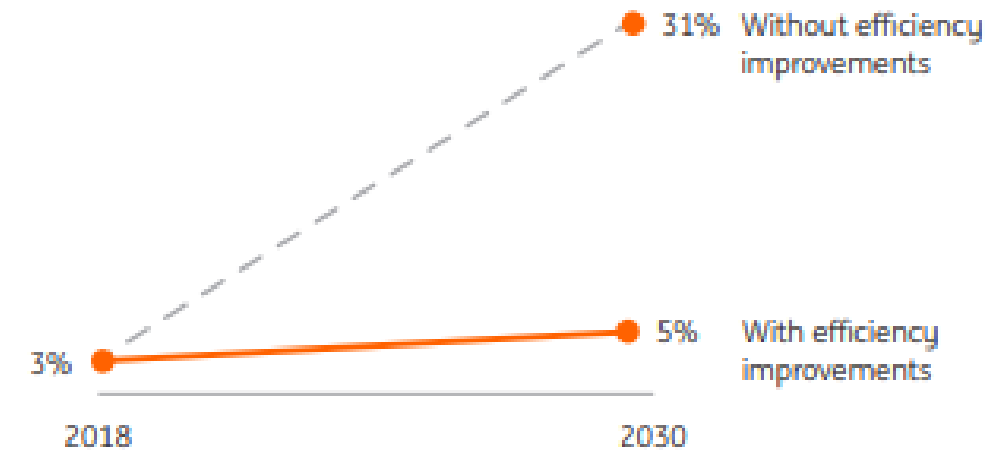

Source: ING Economics Department calculations, BNEF

ONTWERPER CONTROLE

KIJKER CONTROLE



① Wat **ZIEN** we?

② Wat **BETEKENT** het?

③ Wat **BETEKENT** het **VOOR MIJ**?



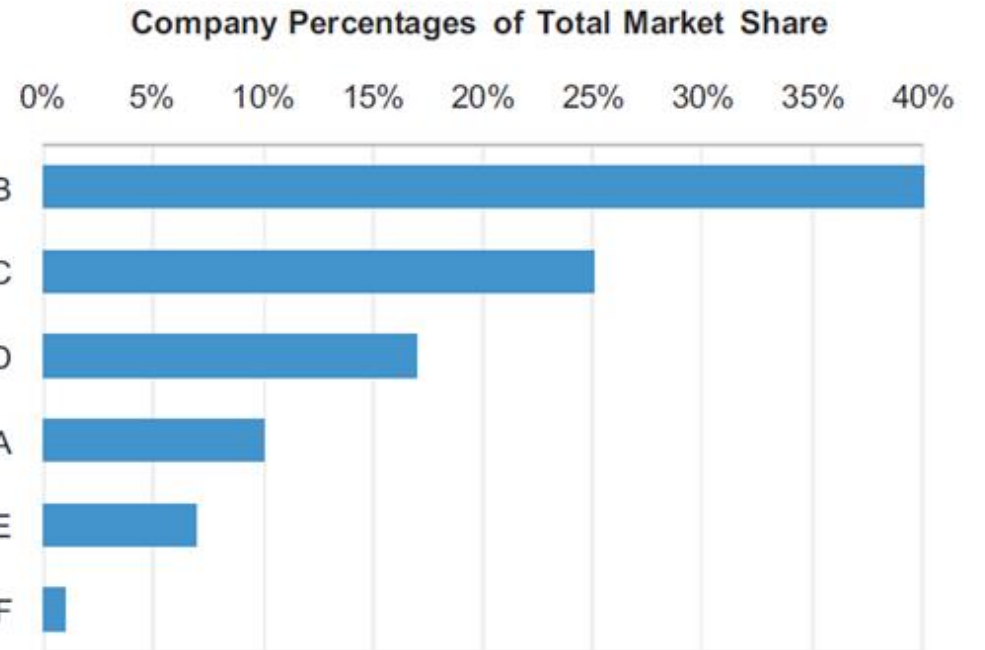
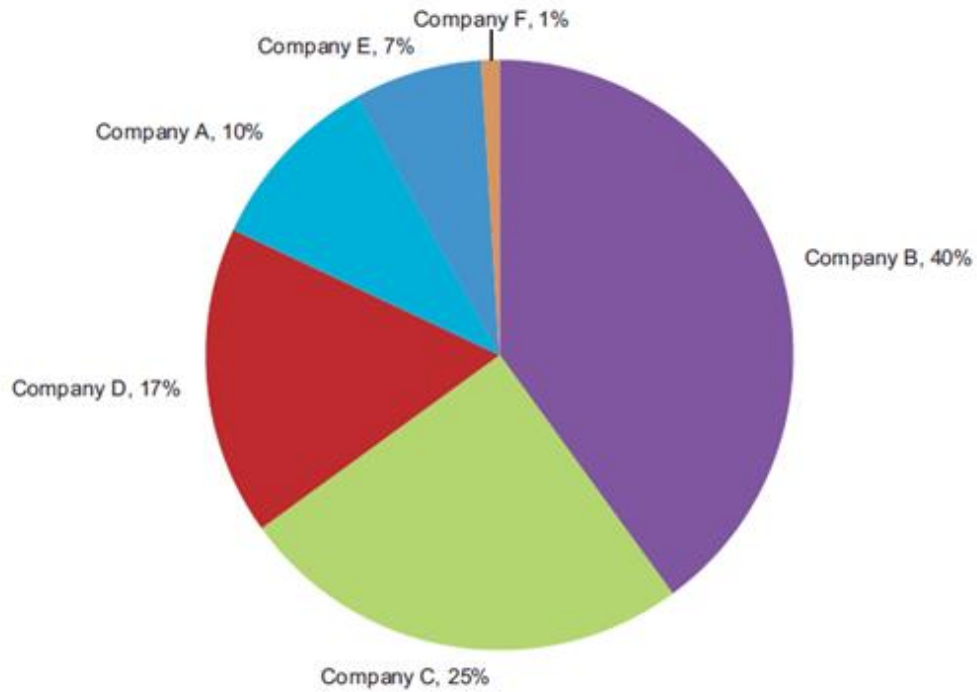

Overview

Region SEEMEA: Trade Receivables Dashboard as of end jul 2020 (Std.21)



4,636

-2.45% vs Jun 2020

TR Balance in MDKK

Balance developing

TR Balance in MDKK	4,636	●
TR Balance vs AB2021	4,636	●
Driven by higher sales vs AB2021	+9,126	●
Driven by higher collections vs AB2021	-4,490	●
TR Balance vs AB2021	444.12	



825

+107% vs Jun 2020

Overdue TR Balance in MDKK

Overdue TR aging

Overdue TR Balance %	18%	●
TR Balance vs AB2021	4,636	●
Driven by higher sales vs AB2021	+9,126	●
Driven by higher collections vs AB2021	-4,490	●
TR Balance vs AB2021	3456	



112.5

+0.7 vs Jun 2020

Avg. YTD DSO in Days

Days ahead (*)

Avg. YTD DSO vs AB21	18%	●
TR Balance vs AB2021	4,636	●
Driven by lower sales vs AB2021	+9,126	●
Driven by lower collections vs AB2021	-4,490	●

* How many days are we ahead or behind in terms of collections?

KPI: Operating Profit | P&L Development

How resources are allocated over time?

Show in percentage?

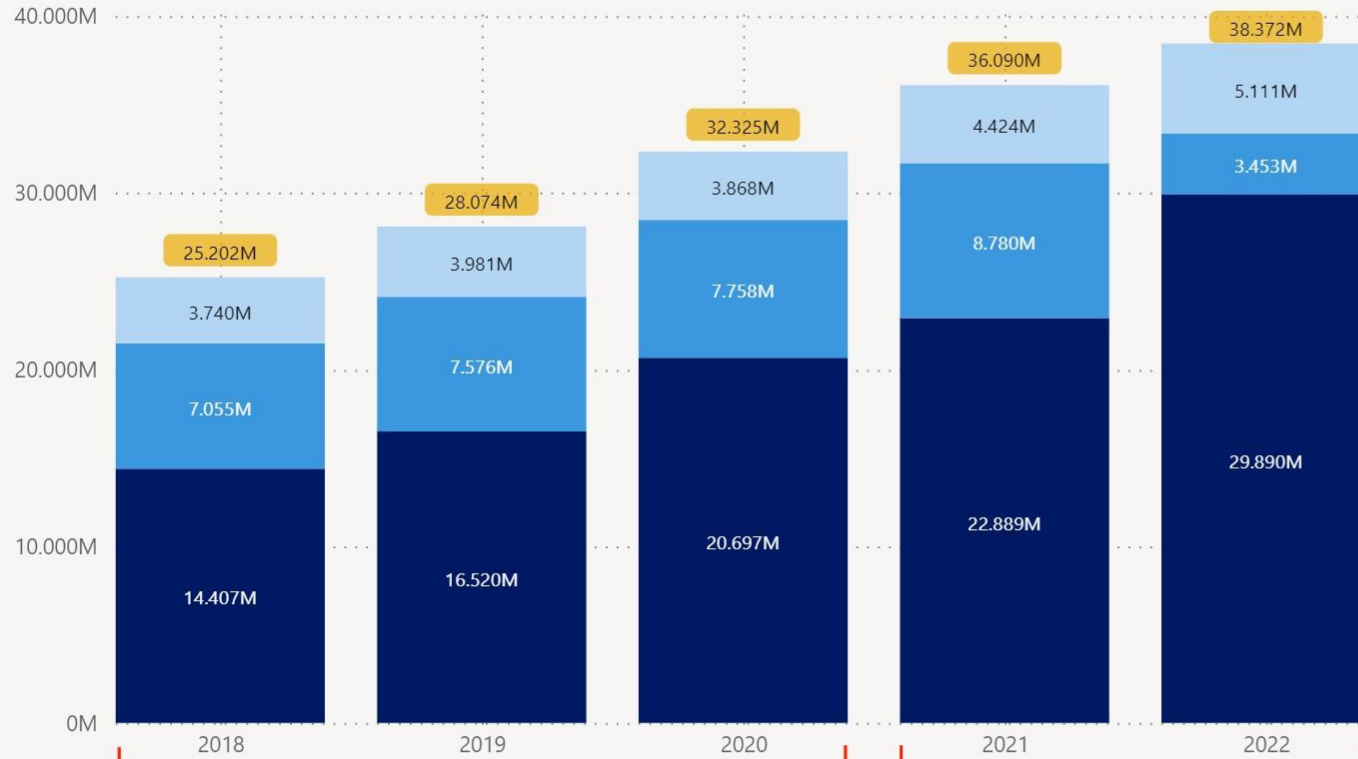

REA

RE

Legend



OP



TOC



COGS



Sales

Choose a therapy split filter



- GLP-1
- Total insulin
- Other diabetes care
- Obesity care
- Total biopharm
- Others

Choose a budget



RE

** Nothing. It's a classic, after all. But we all get bored from seeing the same thing over and over again. Besides, surprising the rest of your design team with something else other than Lorem Ipsum might rip quite a few laughs and smiles.*



ANWB

Welcome

Overview

Sales vs. Costs

Customer Acquisition Cost

Revenue per FTE

Return on Assets

Customer Satisfaction Score

Total Pipeline Value

Website

Lidmaatschap

Route planner

Contact & Service

Go back

Total Sales and Sales Var % by Manufacturer (groups)



Financial KPI's in 2022



Balance developing

TR Balance In MDKK	\$11,161,785
TR Balance vs AB2021	23.58%
Driven by higher sales vs AB2021	€ 4,990,799,423
Higher collections vs AB2021	All Season
Customer Acquisition Cost (CAC)	2.74%
Customer Retention Rate (CRR)	11161785
Monthly Recurring Revenue (MRR)	240339



Data warning

In publishing and graphic design, Lorem ipsum is a placeholder text commonly used to demonstrate the visual form.



160K

Company

APUTrading SBBT

Sub Channel

KA-OFF UnLimi... ON-Trade Wine OFF-Trade TD

AR Amount

APU Trading	SBBT
585,81M	16,63bn

AR Overdue 0-14 days	
(Blank)	4,37bn

AR Overdue 15-30 days	
(Blank)	5,49bn

AR Overdue 31-60 days	
(Blank)	4,03bn

AR Overdue 61-90 days	
(Blank)	2,38bn

AR Overdue > 91 days	
0,00	370,87M

Jan Feb Mar Apr

W5

Total Customer	APU Trading	SBBT
255	673,19M	-413,64M

Receivable Amount By Channel

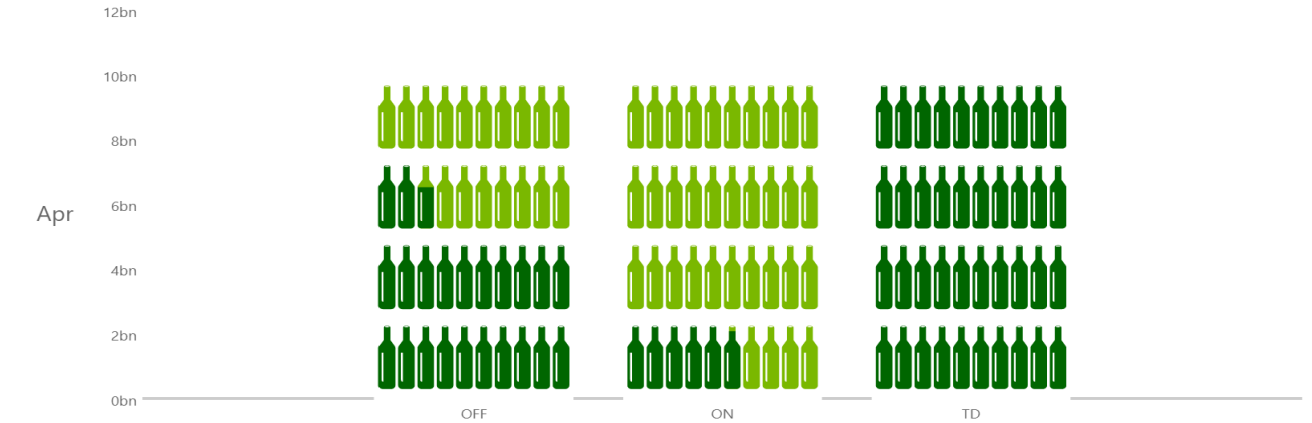

Receivable Amount By Sub Channel

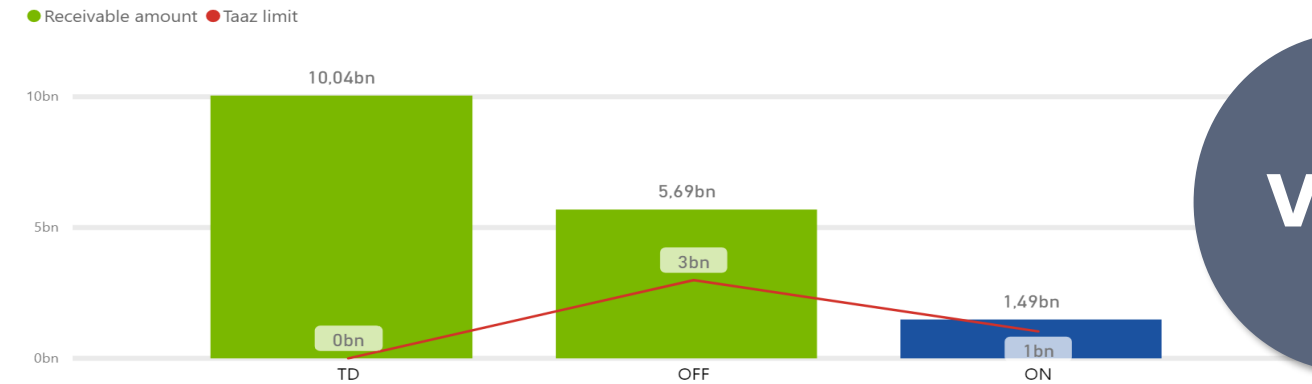

Voor

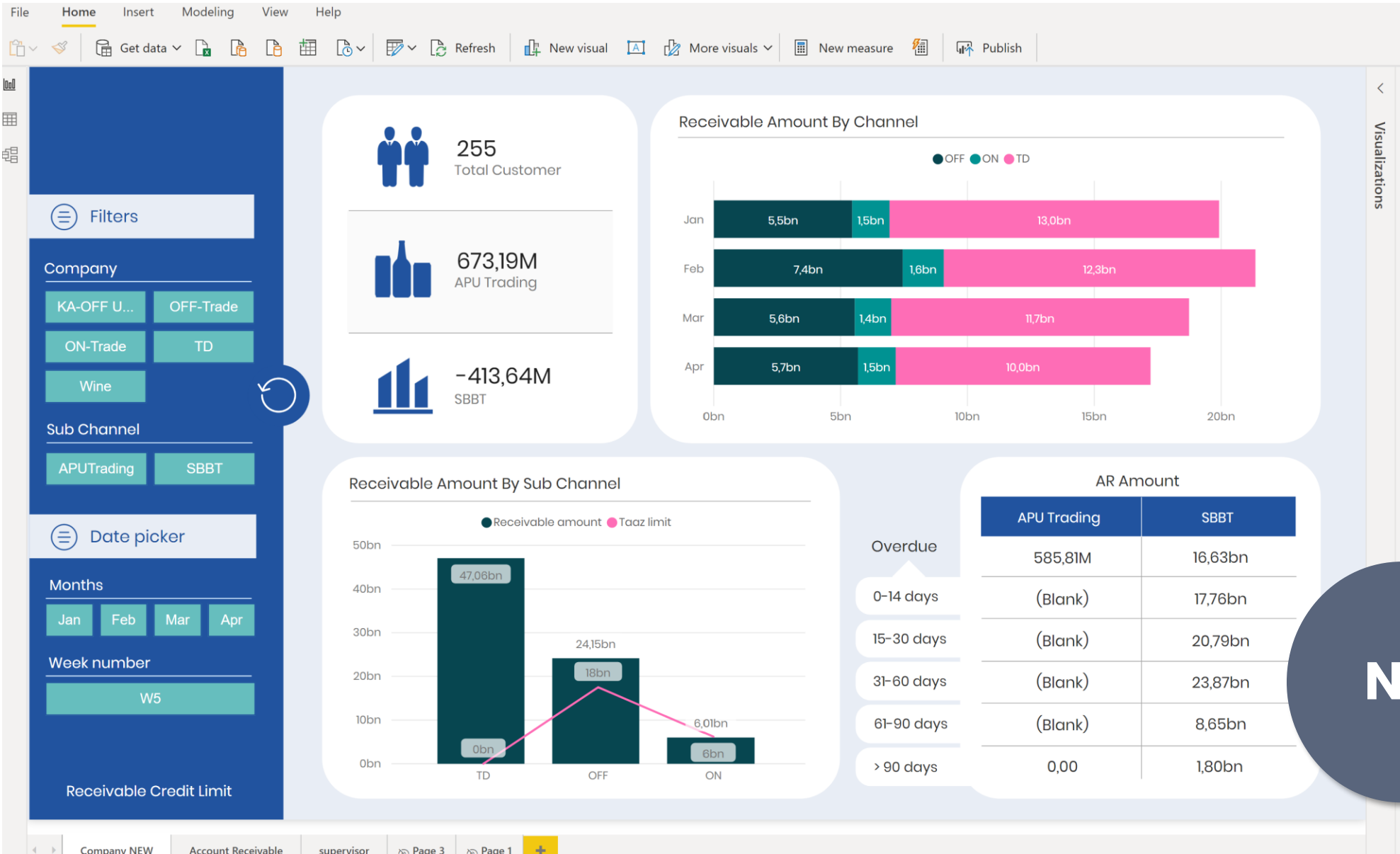

COMPARISON

Display measures compared by their magnitude

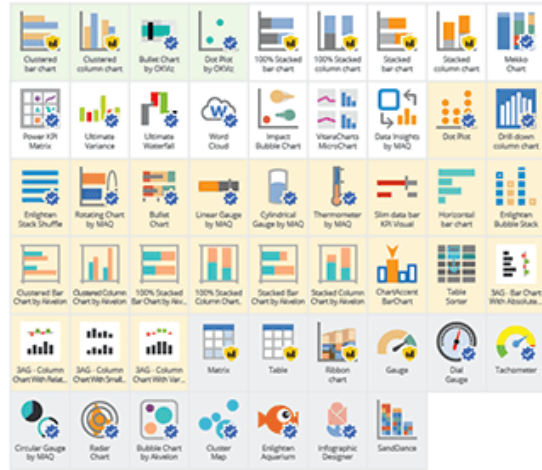

CHANGE O

Display the changing trend



PART-TO-WHOLE

Display the parts of a measure



DISTRIBUTION

Display the distribution of data



Clustered bar chart	Clustered column chart	Bullet Chart by OKViz	Dot Plot by OKViz	100% Stacked bar chart	100% Stacked column chart	Stacked bar chart	Stacked column chart	Mekko Chart
Power KPI Matrix	Ultimate Variance	Ultimate Waterfall	Word Cloud	Impact Bubble Chart	VitarCharts MicroChart	Data Insights by MAQ	Dot Plot	Drill-down column chart
Enlighten Stack Shuffle	Rotating Chart by MAQ	Bullet Chart	Linear Gauge by MAQ	Cylindrical Gauge by MAQ	Thermometer by MAQ	Slim data bar KPI Visual	Horizontal bar chart	Enlighten Bubble Stack
Clustered Bar Chart by Akvelon	Clustered Column Chart by Akvelon	100% Stacked Bar Chart by Akvelon	100% Stacked Column Chart by Akvelon	Stacked Bar Chart by Akvelon	Stacked Column Chart by Akvelon	ChartAccent BarChart	Table Sorter	3AG - Bar Chart With Absolute Values
3AG - Column Chart With Relationships	3AG - Column Chart With Small Values	3AG - Column Chart With Variance	Matrix	Table	Ribbon chart	Gauge	Dial Gauge	Tachometer
Circular Gauge by MAQ	Radar Chart	Bubble Chart by Akvelon	Cluster Map	Enlighten Aquarium	Infographic Designer	SandDance		



**MAXIMALISEER
DATA-INKT RATIO**



**GEbruik CONTRAST
OM DATA TE TONEN**



**BEPERK KLEUREN,
GEbruik VARIANTEN**



**GEbruik GEEN
KLEURVERLOOP**



**VERMIJD 3D EN
"SMOOTHING"**

VERHOEVE
VERHOEVE
VERHOEVE

VERHOEVE
VERHOEVE
VERHOEVE

**LEESBARE
LABELS**



**VOORKOM
HERHALING**



**SORTEER VOOR
MEER BEGRIP**





**REKEN ZOVEEL
MOGELIJK VOOR**



**VEREENVOUDIG
VERGELIJKEN**

10-Stappenplan

1. Inventariseren behoefte stakeholders (wat)
2. Wat is de (achterliggende) vraag (wat)
3. Inventariseren begrippenlijst/gebruikerscodes (kleurgebruik, afkortingen, sjablonen, symbolen etc.) (hoe)
4. Hoe gaan we kpi's meten (hoe)
5. Bewustwording valkuilen gemaakte keuzes (interpretatieverschillen)
6. Concept visualiseren (waarnemen, interpreteren en begrijpen)
7. Kijkerscontrole (draagvlak)  **CIJFERS ZIJN NIET OBJECTIEF, ER IS ALTIJD INTERPRETATIE**
8. Afstemmen, bijsturen, opleiden  **CIJFERS ZIJN GEEN WAARZEGGERS**
9. Definitief visualiseren  **CIJFERS ZIJN GEEN REFLECTIE, HOOGUIT EEN REFERENTIE**
10. In gebruik name en continue ontwikkeling



BEDANKT VOOR JE AANDACHT!

